

# MG1200 - KMG1200

PARAFANGO / COPRICATENA - MUDGUARD / CHAIN-COVER - PASSAGE DE ROUE / PAER-CHAINEKETTENSCHUTZ - GUARDABARROS / CUBRECADENA - PARALAMA

## HONDA CB 750 HORNET (2023)

N°	Descrizione/Description	Caratteristiche/Features	Codice/Code	Quantità/Quantity
1	Parafango - Mudguard - Passage De Roue Kettenschutz - Guardabarros - Paralama	-	1200MG	1
2	Supporto - Support - Support Halterung - Soporte - Apoio	-	GL5577V	1
3	Vite - Screw - Vis - Schraube Tornillo - Parafuso	M6x20 TECF	620TECF	2
4	Rondella spaccata - Split washer - Scheibe Rondelle fendue - Arandela seccionada - Arruela Dentada	Foro Ø6mm	Z1063	2
5	MOUSSE	15X5X500mm	MOUSSE4	1
6	Componenti Originali - Original Parts - Parties Originales Original Bauteile - Componentes Originales - Componentes Originais	-	-	-

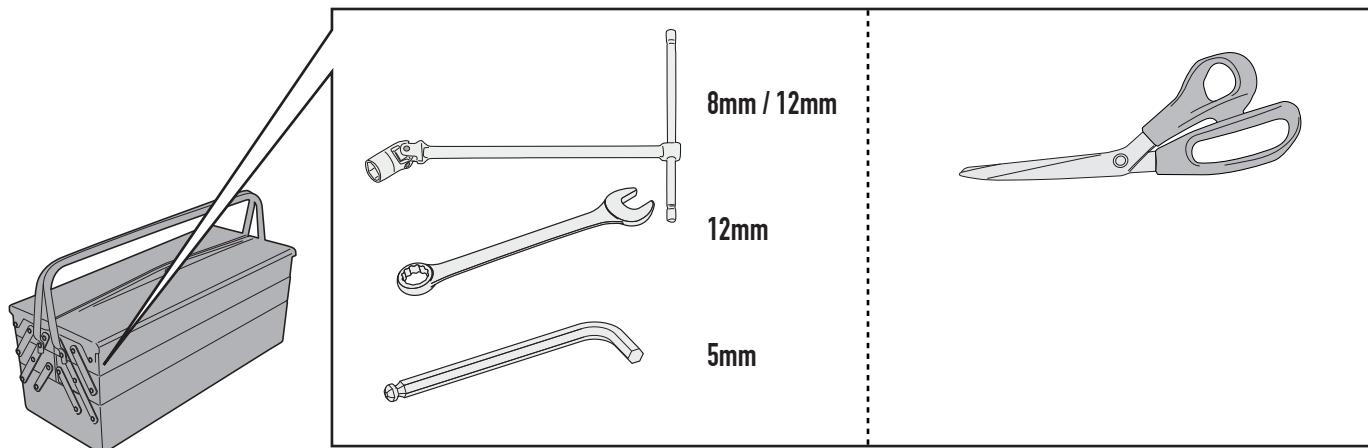
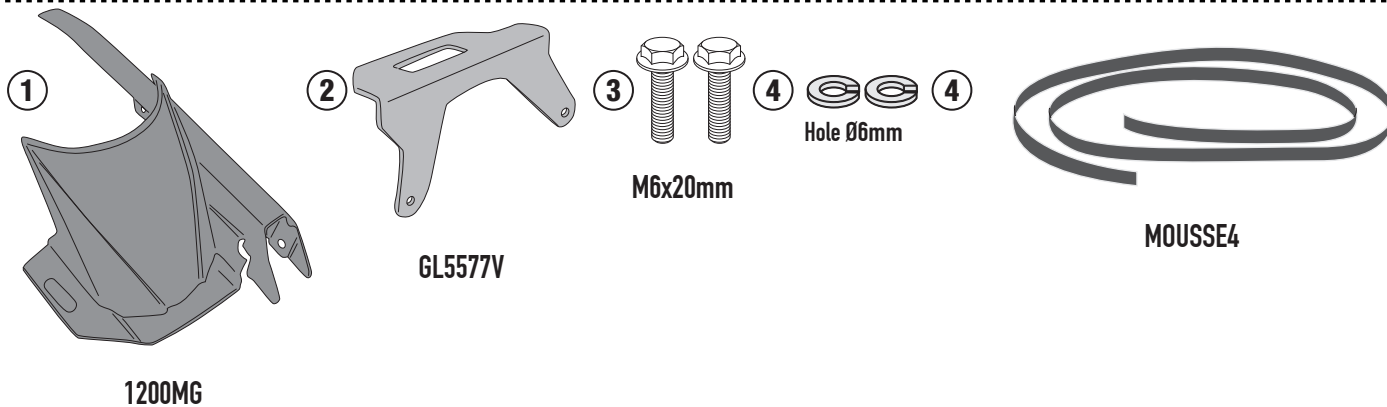

IT\_ Nel caso in cui sulle viti originali sia presente del frenafili, ripristinarlo durante il montaggio dell'accessorio.

EN\_ If there is threadlocker on the original screws, use threadlocker when mounting the accessory.

DE\_ Falls sich auf den Originalschrauben Schraubensicherungsstoff befand, sollte dieser auch bei der Montage des Zubehörs wieder aufgetragen werden

FR\_ Si du frein filet est présent sur les vis d'origine, l'appliquer également lors du montage de l'accessoire

ES\_ En caso de que el fijador de roscas se encuentre presente en los tornillos originales, colocarlo nuevamente en el montaje del accesorio

PT\_ Se houver trava rosca nos parafusos originais, inserir novamente durante a montagem do acessório

# MG1200 - KMG1200

PARAFANGO / COPRICATENA - MUDGUARD / CHAIN-COVER - PASSAGE DE ROUE / PAER-CHAIKETTENSCHUTZ - GUARDABARROS / CUBRECADENA - PARALAMA

## HONDA CB 750 HORNET (2023)

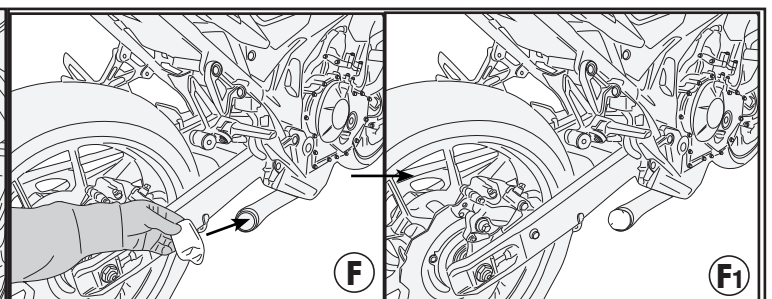
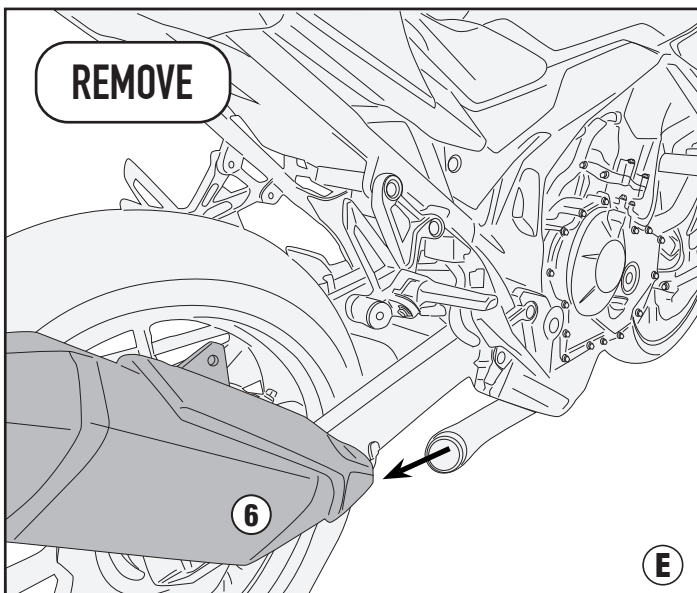
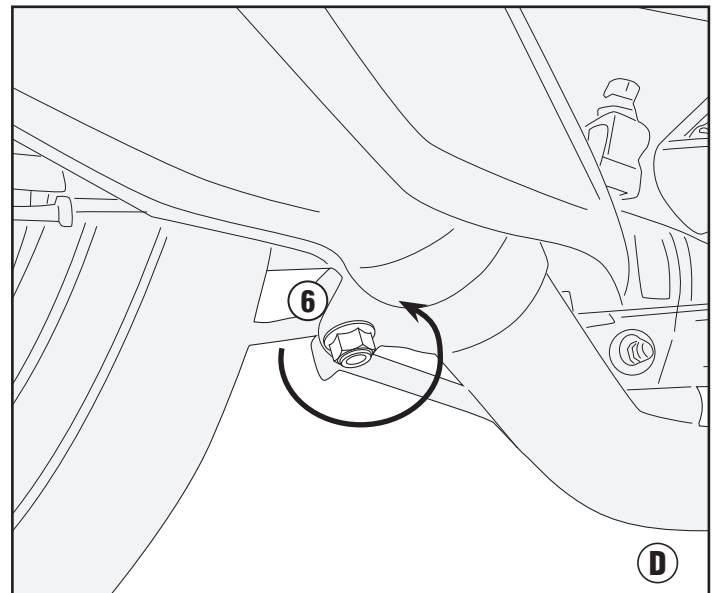
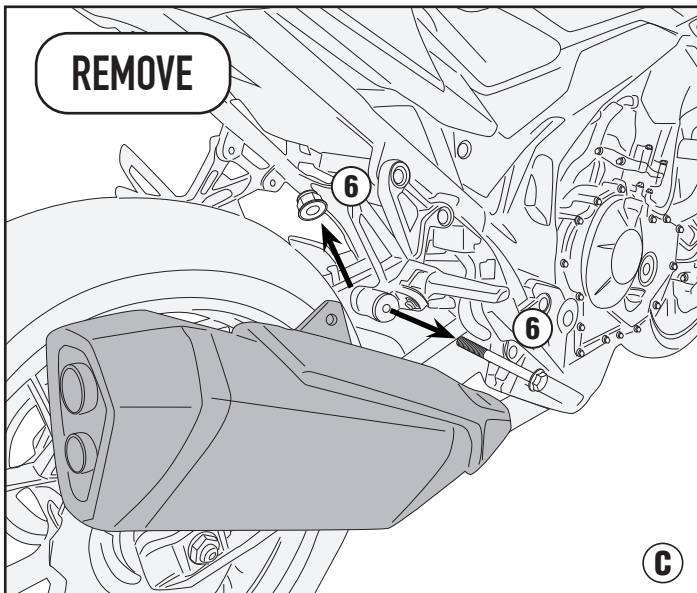
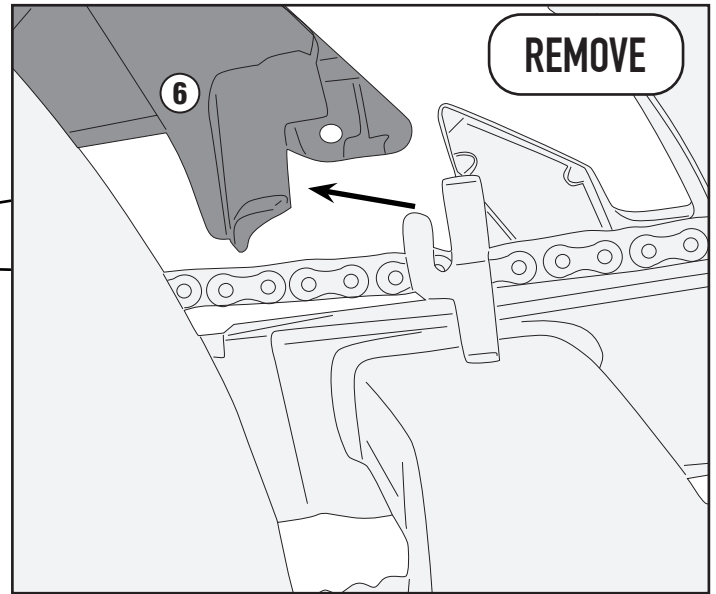
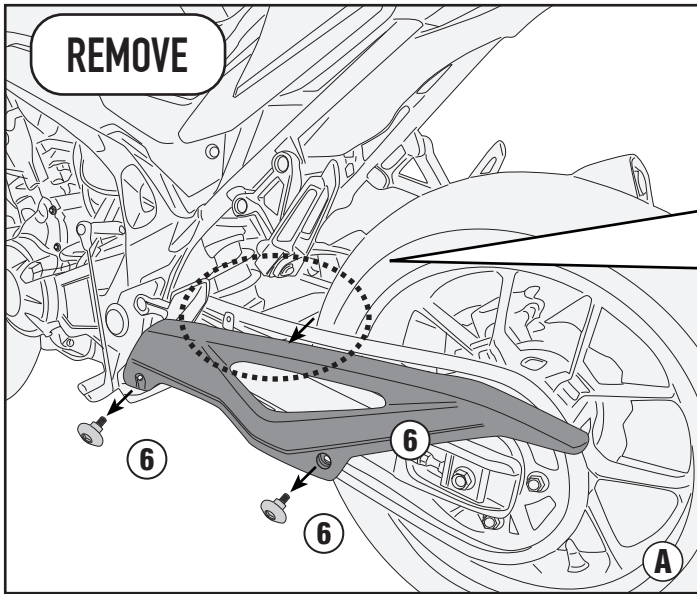

- PRIMA DI PROCEDERE APPLICARE UN PANNO SUL FORO DELLO SCARICO PER EVITARE DI FARVI CADERE ACCIDENTALMENTE DELLE VITI. MOTORE FREDDO.
- BEFORE STARTING, APPLY A CLOTH TO CLOSE THE EXHAUST HOLE TO PREVENT SCREWS FROM FALLING INSIDE IT. COLD ENGINE.
- AVANT DE COMMENCER, APPLIQUEZ CHIFFON SUR LE MOTO D'ÉCHAPPEMENT POUR ÉVITER LA PERTE DE VIS. MOTEUR FROID.
- BEVOR SIE BEGINNEN, LEGEN SIE EINEN LAPPEN AUF DEN AUSPUFF, UM DEN VERLUST VON SCHRAUBEN VERMEIDEN. KALTER MOTOR.
- ANTES DE COMENZAR, APLIQUE UN POCO DE CINTA EN EL ESCAPE PARA EVITAR LA PERDIDA DE LOS TORNILLOS. MOTOR FRIO
- ANTES DE COMECAR, APLIQUE UM POUÇO DE FITA ADESIVA PARA FECHAR O ESCAPAMENTO PARA EVITAR QUE OS PARAFUSOS CAIAM DENTRO. MOTOR FRIO

# MG1200 - KMG1200

PARAFANGO / COPRICATENA - MUDGUARD / CHAIN-COVER - PASSAGE DE ROUE / PAER-CHAIKETTENSCHUTZ - GUARDABARROS / CUBRECADENA - PARALAMA

## HONDA CB 750 HORNET (2023)

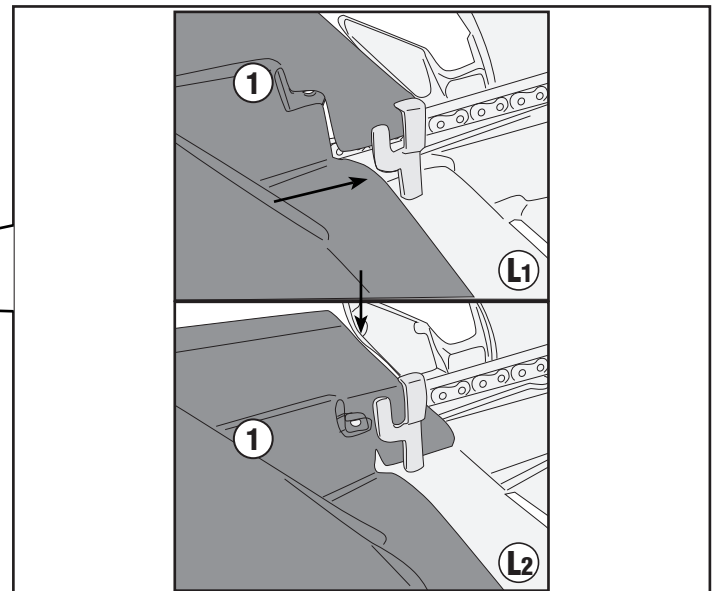
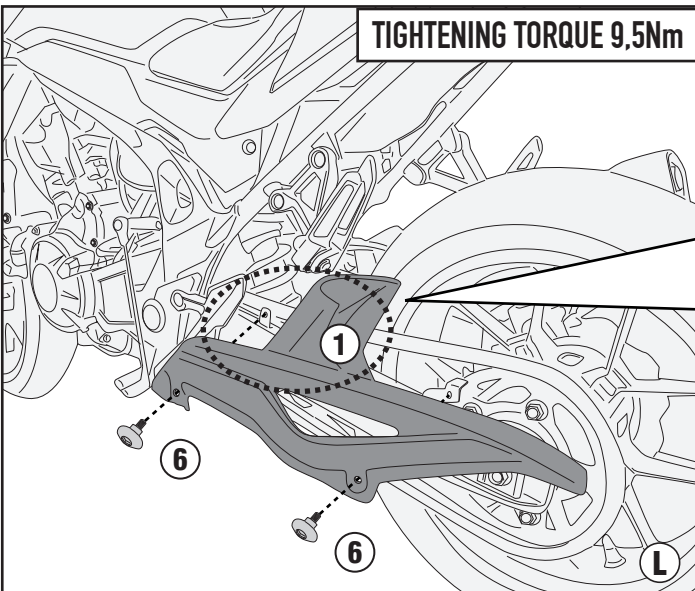
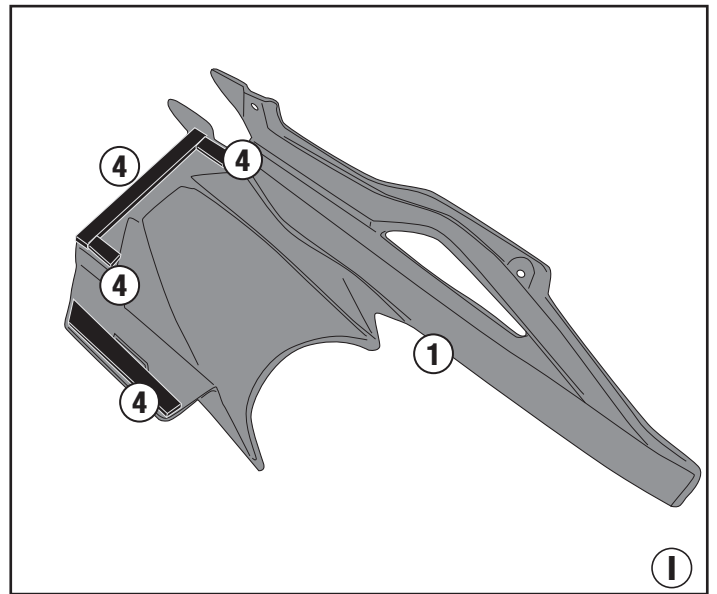
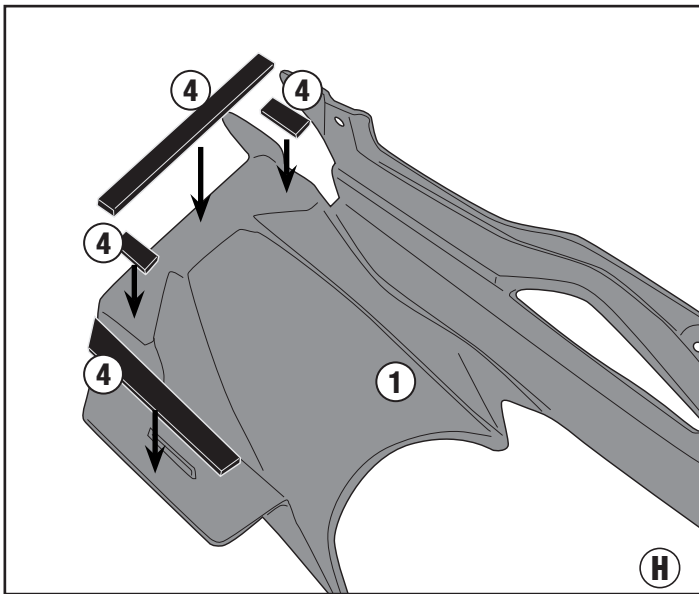
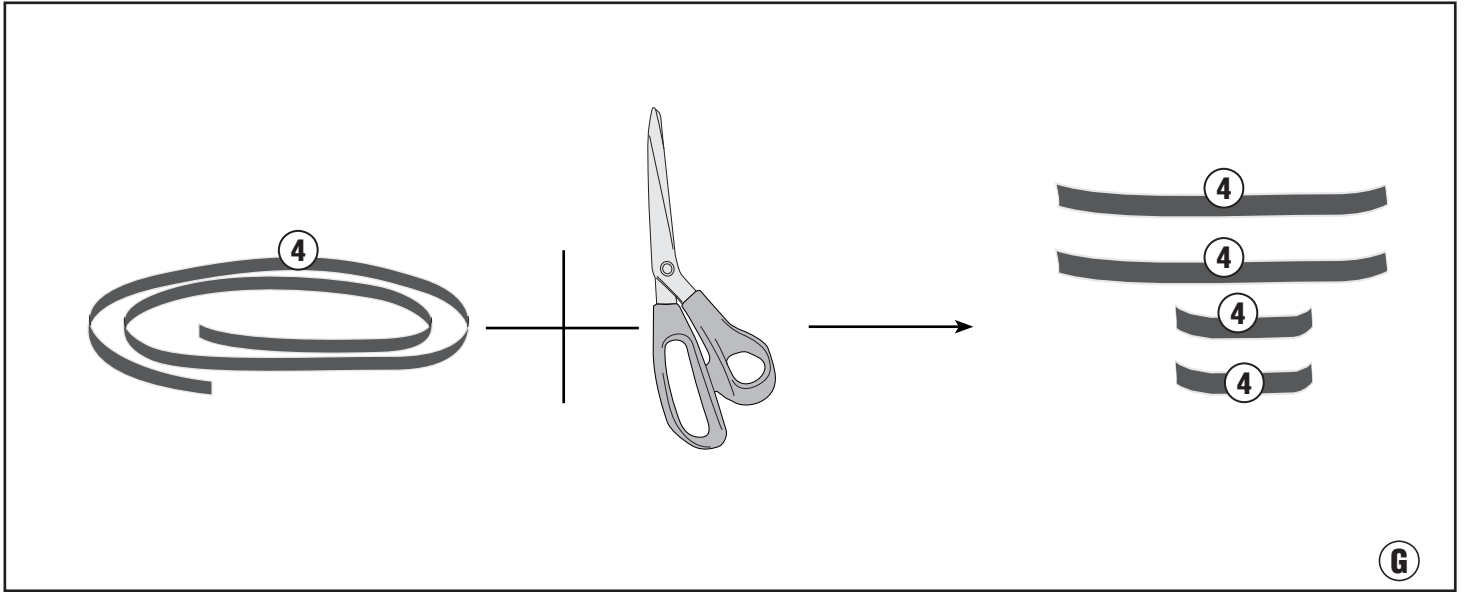

# MG1200 - KMG1200

PARAFANGO / COPRICATENA - MUDGUARD / CHAIN-COVER - PASSAGE DE ROUE / PAER-CHAINEKETTENSCHUTZ - GUARDABARROS / CUBRECADENA - PARALAMA

## HONDA CB 750 HORNET (2023)

